



FlexLock® Flange Adaptor

CT Series

APPLICATION

Mechanical, end-load bearing flanged fitting to connect a plain ended Steel gas pipe to a standard flange for above or below ground installations.

DESCRIPTION

Flexlock® Flange Adaptors are dedicated mechanical locking fittings for standard Steel pipes which provide full end load retention up to their pressure rating. The outlet flange has multiple drillings suitable for standard PN16 flanges as well as some PN10, BS10 Table E and ANSI 150 types. The fitting can accommodate angular misalignment up to 3° between pipe and flange.

CONSTRUCTION

- Body (1) & End Ring (2): SG Iron or Steel
- Gasket (3): NBR Rubber
- Gripper (4): Stainless Steel
- Fasteners (5): HT Steel with Sheraplex coating
- Corrosion protection: Rilsan Nylon coating

INSTALLATION

The Flexlock® Flange Adaptor should be installed following the instructions for the setting gap positioning and tightening of fasteners included with the product.

M12 Fasteners – Torque to 55-65 Nm.

M16 Fasteners – Torque to 95–120 Nm.

Rotation of the Body allows for easy alignment with mating flanges.



Every effort has been made to ensure that the information contained in this publication is accurate at the time of publishing. Crane Ltd assumes no responsibility or liability for typographical errors or omissions or for any misinterpretation of the information within the publication & reserves the right to change without notice.

SPECIFICATION

Maximum Operating Pressure (MOP) = 6.0 Bar.

PE X FLANGE SIZES

Available in sizes from 50mm x DN50 to 300mm x DN300.

DIMENSIONS

All dimensions in mm.

SIZE = DIAMETER x NOMINAL FLANGE SIZE (PN16)							
SIZE	PIPE Ø	L	S	A	F	SET GAP	
						MIN	MAX
50 x 50	60.3	124	75	160	16	10	30
65 x 65	76.1	124	75	180	16	10	30
80 x 80	88.9	124	75	195	16	10	30
100 x 100	114.3	134	75	215	16	10	30
150 x 150	165.1	134	75	285	25	10	30
150 x 150	168.3	133	75	286	19	10	30
200 x 200	219.1	134	75	340	25	10	30
250 x 250	273.0	146	90	405	19	10	30
300 x 300	232.9	155	90	467	19	10	30

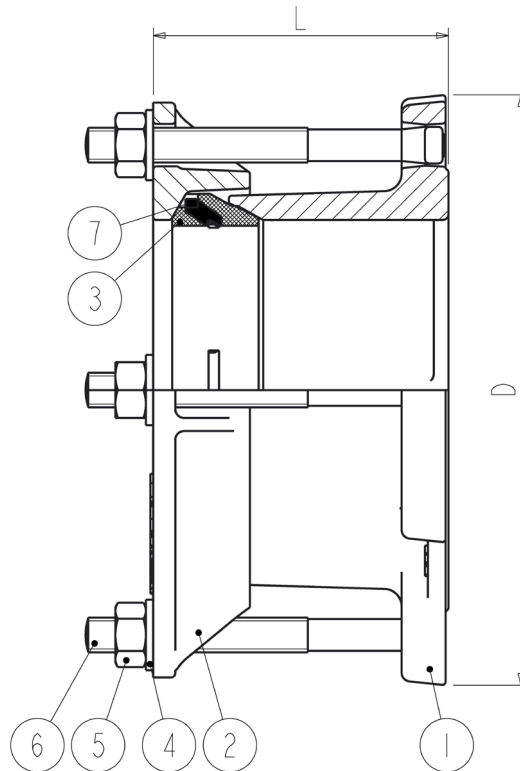

To visit our Video Library go to:
www.youtube.com/user/CraneBSU



46-48 WILBURY WAY, HITCHIN,
 HERTFORDSHIRE, SG4 0UD
 TELEPHONE: +44 (0)1462 443225
 TELEPHONE: +44 (0)1462 443226
 FAX: +44 (0)1462 443311
 EMAIL: sales@wask-uk.com
www.wask-uk.com



FM 00311 EMS 553775

- Designed and manufactured under quality management systems in accordance with BS EN ISO 9001.

Every effort has been made to ensure that the information contained in this publication is accurate at the time of publishing. Crane Ltd assumes no responsibility or liability for typographical errors or omissions or for any misinterpretation of the information within the publication and reserves the right to change without notice.

W_FFA_0121_v1