



# MaxiDaptor® Flange Adaptor

## CT Series

### APPLICATION

Wide tolerance mechanical, non end-load bearing fitting to connect a plain end gas pipe to a standard flange, primarily for underground installations.

### DESCRIPTION

MaxiDaptors comprise a wide tolerance joint, compatible with a number of different nominal pipes diameters. The outlet flange has multiple drillings suitable for standard PN 16 flanges as well as some PN 10, BS 10 Table D & E and ANSI 125/150 types. The fitting can accommodate angular misalignment up to 3° between pipe and flange.

### CONSTRUCTION

- Body & End Ring: SG Iron or Steel
- Gasket: NBR Rubber
- Fasteners: Steel with Sheraplex coating
- Corrosion protection: Rilsan Nylon coating

### INSTALLATION

The MaxiDaptor should be installed following the instructions for the setting gap positioning and tightening of fasteners included with the product.

M 12 Fasteners – Torque to 55-65 Nm.

Rotation of the Body allows for easy alignment with mating flanges.

### SPECIFICATION

Maximum Operating Pressure (MOP) = 6.0 Bar.



Every effort has been made to ensure that the information contained in this publication is accurate at the time of publishing. Crane Ltd assumes no responsibility or liability for typographical errors or omissions or for any misinterpretation of the information within the publication & reserves the right to change without notice.

**PE X FLANGE SIZES**

Available in sizes from 50mm x DN50 to 600mm x DN600.

**DIMENSIONS**

All dimensions in mm. Consult the factory for other optional sizes above 300mm.

SIZE = NOMINAL DIAMETER x NOMINAL FLANGE SIZE (PN16)							
SIZE	S		L	A	T	M	
	MIN	MAX				MIN	MAX
50 x 50	57	74	124	75	5	20	40
65 x 65	63	85	124	75	5	20	40
80 x 80	85	107	124	75	5	20	40
100 x 100	107	132	134	75	5	20	40
125 x 125	132	158	134	75	5	20	40
150 x 150	158	184	134	75	5	20	40
175 x 175	189	212	133	75	5	25	40
200 x 200	218	244	134	75	5	25	40
225 x 250	243	269	144	85	5	25	50
250 x 250	266	295	146	85	5	25	50
300 x 300	315	349	155	100	5	25	60
350 x 350	375	392	218	120	* 18	45	68
400 x 400	434	451	303	205	* 18	130	153
450 x 450	487	504	218	120	* 23	45	68
500 x 500	540	557	218	120	* 23	45	68
600 x 600	645	662	218	120	* 23	45	68

\*T dimension above 300mm is the Flange thickness.

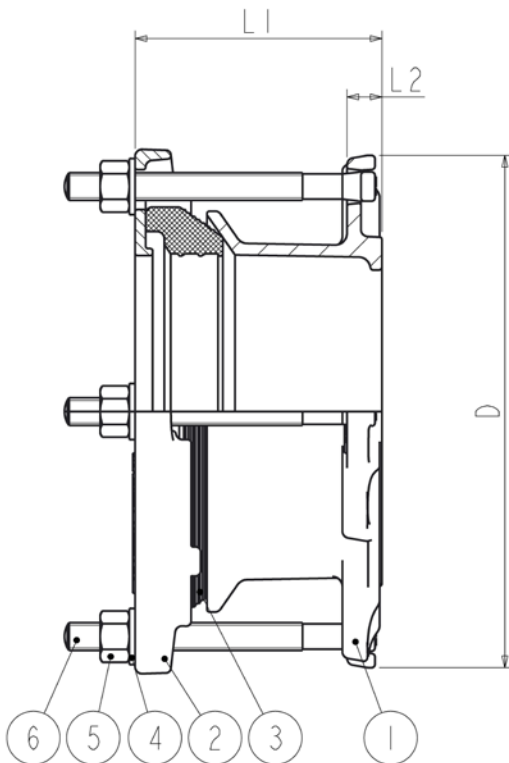

To visit our Video Library go to:  
[www.youtube.com/user/CraneBSU](http://www.youtube.com/user/CraneBSU)



46-48 WILBURY WAY, HITCHIN,  
 HERTFORDSHIRE, SG4 0UD  
 TELEPHONE: +44 (0)1462 443225  
 TELEPHONE: +44 (0)1462 443226  
 FAX: +44 (0)1462 443311  
 EMAIL: [sales@wask-uk.com](mailto:sales@wask-uk.com)  
[www.wask-uk.com](http://www.wask-uk.com)



FM 00311 EMS 553775

• Designed and manufactured under quality management systems in accordance with BS EN ISO 9001.

Every effort has been made to ensure that the information contained in this publication is accurate at the time of publishing. Crane Ltd assumes no responsibility or liability for typographical errors or omissions or for any misinterpretation of the information within the publication and reserves the right to change without notice.

W\_MFA\_1220\_V1