



MaxiFit® Pipe Coupling

CT Series

APPLICATION

Wide tolerance mechanical, non end-load bearing fitting to connect two plain ended gas pipes, primarily for underground installations.

DESCRIPTION

MaxiFit comprises two wide tolerance joints, compatible with a number of different nominal pipes diameters which can be different at each end of the coupling. The fitting can accommodate angular misalignment up to 6° between pipes.

CONSTRUCTION

- Sleeve & End Ring: SG Iron or Steel
- Gasket: NBR Rubber
- Fasteners: Steel with Sheraplex coating
- Corrosion protection: Rilsan Nylon coating

INSTALLATION

The MaxiFit should be installed following the instructions for the setting gap positioning and tightening of fasteners included with the product.

M12 Fasteners – Torque to 55-65 Nm.

SPECIFICATION

Maximum Operating Pressure (MOP) = 6.0 Bar.



Every effort has been made to ensure that the information contained in this publication is accurate at the time of publishing. Crane Ltd assumes no responsibility or liability for typographical errors or omissions or for any misinterpretation of the information within the publication & reserves the right to change without notice.

PIPE SIZES

Available in sizes from 50mm to 300mm, consult the factory for other sizes above 300mm.

Stepped types are also available.

DIMENSIONS

Dimension shown in mm.

SIZE	DIA RANGE		L	A	T	M	SET GAP	
	MIN	MAX					MIN	MAX
	50 (2")	57					74	190
65 (2½")	63	85	190	95	4.5	174	20	40
80 (3")	85	107	190	95	4.5	196	20	40
100 (4")	107	132	190	95	4.5	225	20	40
125 (5")	132	158	190	95	5	255	20	40
150 (6")	158	184	190	95	5	281	20	40
175 (7")	189	212	230	130	5	307	25	50
200 (8")	218	244	230	130	5	343	25	50
225 (9")	243	269	230	130	5	368	25	50
250 (10")	266	295	230	130	5	400	25	50
300 (12")	315	349	230	130	5	463	25	50

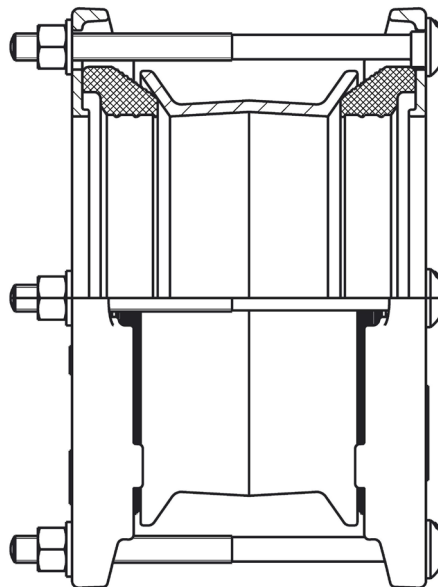

To visit our Video Library go to:
www.youtube.com/user/CraneBSU



46-48 WILBURY WAY, HITCHIN,
 HERTFORDSHIRE, SG4 0UD
 TELEPHONE: +44 (0)1462 443225
 TELEPHONE: +44 (0)1462 443226
 FAX: +44 (0)1462 443311
 EMAIL: sales@wask-uk.com
www.wask-uk.com



FM 00311 EMS 553775

- Designed and manufactured under quality management systems in accordance with BS EN ISO 9001.

Every effort has been made to ensure that the information contained in this publication is accurate at the time of publishing. Crane Ltd assumes no responsibility or liability for typographical errors or omissions or for any misinterpretation of the information within the publication and reserves the right to change without notice.

W_MPC_0121_v1