



PECAT® Below Ground Entry Weld

AE Series

APPLICATION

Provides a high strength building entry fitting for connecting a polyethylene gas service pipe to a metering or pressure reduction installation via a steel through wall pipe for a below ground connection.

DESCRIPTION

Comprising a PECAT® mechanical joint, factory assembled with straight length of PE pipe within a Steel protective through wall Plain outlet for welding a connection to the ECV or internal pipe work.

CONSTRUCTION

- Body (3): Steel
- Outer Sleeve (2): Steel (Coated)
- Outer Sleeve cover: PE – 90mm only
- Inlet pipe (1): PE to GIS/PL2-2
- Sleeve Seal (5): EPDM Rubber
- Corrosion protection: PE or Epoxy/Polyester coating

INSTALLATION

Below Ground Entry's are supplied suitable for site jointing by electro fusion only. No adjustment to through wall length is possible, see table below for available length options.

Please refer to the PE fitting manufacturer's instructions for details on electro fusion welding procedures.



Every effort has been made to ensure that the information contained in this publication is accurate at the time of publishing. Crane Ltd assumes no responsibility or liability for typographical errors or omissions or for any misinterpretation of the information within the publication & reserves the right to change without notice.

SPECIFICATION

Meets GIS/PL3:2014 requirements, BSI Kite Mark certified - KM535530.
Maximum Operating Pressure (MOP) = 2.0 Bar.

PE X OUTLET SIZES

90mm SDR11 x 3" to 315mm SDR21 x 12".

DIMENSIONS

Note: consult the factory for L2 sizes not shown in table on the right.

SIZE = PE DIAMETER x OUTLET SIZE & TYPE						
SIZE	D1	D2	D3	L1	L2	L3
90 SDR11 x 3"	127	90	88.9	500	500	500
90 SDR11 x 3"	127	90	88.9	500	750	500
125 SDR11 x 4"	141	125	114.3	500	500	500
125 SDR11 x 4"	141	125	114.3	500	750	500
125 SDR11 x 4"	141	125	114.3	500	1000	500
125 SDR11 x 4"	141	125	114.3	500	1500	500
180 SDR17.6 x 6"	204	180	168.3	500	500	500
180 SDR17.6 x 6"	204	180	168.3	500	750	500
180 SDR17.6 x 6"	204	180	168.3	500	1000	500
180 SDR17.6 x 6"	204	180	168.3	300	1200	500
250 SDR17.6 x 8"	281	250	219.1	800	1200	500
315 SDR21 x 10"	345	315	273.0	800	1200	250
315 SDR21 x 12"	345	315	323.8	500	750	1000

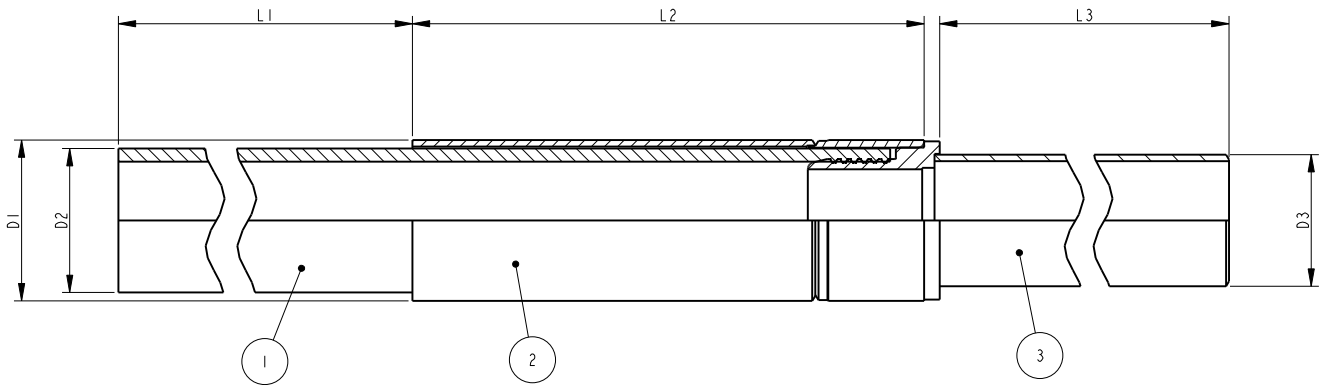

To visit our Video Library go to:
www.youtube.com/user/CraneBSU



46-48 WILBURY WAY, HITCHIN,
HERTFORDSHIRE, SG4 0UD
TELEPHONE: +44 (0)1462 443225
TELEPHONE: +44 (0)1462 443226
FAX: +44 (0)1462 443311
EMAIL: sales@wask-uk.com
www.wask-uk.com



FM 00311 EMS 553775

• Designed and manufactured under quality management systems in accordance with BS EN ISO 9001.

Every effort has been made to ensure that the information contained in this publication is accurate at the time of publishing. Crane Ltd assumes no responsibility or liability for typographical errors or omissions or for any misinterpretation of the information within the publication and reserves the right to change without notice.

W_PBGW_0121_V1