

FLEX-GRIP® COUPLING STEEL & POLYETHYLENE PIPE

MATERIALS OF CONSTRUCTION

Body and nuts

Malleable cast iron BS6681 Grade W40-05

Gaskets

For gas, compressed air and oil – Nitrile:
DIN 3535 Part 1 and 3, BS 2494 Grade G

For water – EPDM

WRC 5.01.02, BSEN 681-1

Collet

For steel pipe: Steel BS 970, 060 A67

Insert

For P.E. pipe: Mild steel to BS 1449 Hr 1
and BS 1449 Cr 1

Washer

Zinc plated mild steel to BS 6258 Gr 600 or
acetal

Finish

Available in a Xylan, galvanised or black finish.

PREPARATION OF THE PIPE ENDS

Where surface corrosion and/or debris is present on metallic pipes, this should be removed using a wire brush. Ensure pipe ends are cut square to within 1mm.

PIPE MATERIAL				
STEEL		POLYETHYLENE (PE)		
O/D (ins)	Torque (Nm)	O/D (mm)	Torque (Nm)	SDR
½	55	20	35	9
¾	70	25	37	11
1	105	32	50	11
1¼	130	-	-	-
1½	165	-	-	-
2	200	63	100	11 & 13.6
2½	300	-	-	-
3	400	-	-	-

INSERTION OF PIPE INTO THE FLEX-GRIP COUPLING

Metallic Pipe

Insert the end of the pipe into the Flex-Grip Coupling, ensuring that the end extends beyond the internal rubber seal. Tighten the end nut to the recommended torque value.

Polyethylene Pipe

Unscrew the end nut on the Flex-Grip Coupling: remove the steel/acetal washer and gasket and slide all three (in order) approximately 300mm down the length of the PE pipe. Remove the insert from the Flex-Grip Coupling and push

onto the end of the pipe until the wall of the polyethylene becomes visible in the circular inspection hole of the insert. Should the inner and outer insert parts become separated prior to assembly, ensure that the outer is fitted to the pipe before fitting the inner into the PE pipe. Locate the PE pipe, complete with insert attached, back into the Flex-Grip Coupling. Slide the gasket, steel/acetal ring and end nut back up the pipe and reassemble. Tighten the end nut to the recommended torque.

IMPORTANT: When connecting two metallic pipes it is essential that a small relative movement between pipe and fitting can occur during tightening.

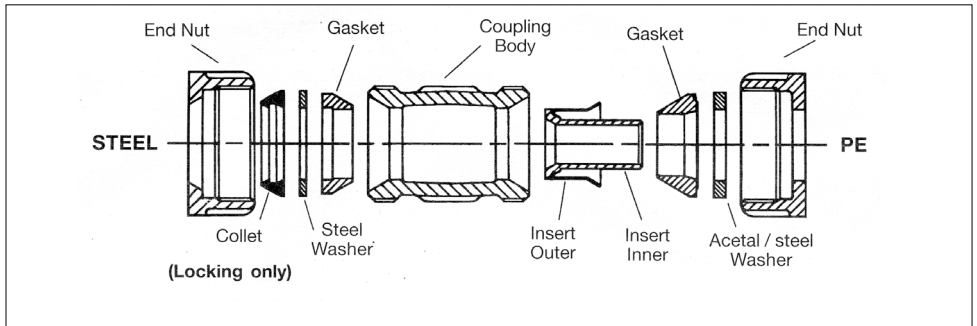

PLEASE NOTE

When using a Flex-Grip coupling designed to connect steel pipe to Polyethylene pipe, ensure that each is inserted into the correct end of the Flex-Grip coupling.

For further information on WASK products and services contact our Sales Department detailed below.



46-48 WILBURY WAY, HITCHIN,
HERTFORDSHIRE, SG4 0UD

TELEPHONE: +44 (0)1462 443225
TELEPHONE: +44 (0)1462 443226
FAX: +44 (0)1462 443311
EMAIL: sales@wask-uk.com

www.wask-uk.com



ISO 14001 Reg No. EMS 78657



To visit our Video Library go to:
www.youtube.com/user/CraneBSU

Designed & manufactured under quality management systems in accordance with BS EN ISO 9001:2008

Every effort has been made to ensure that the information contained in this publication is accurate at the time of publishing. Crane Ltd assumes no responsibility or liability for typographical errors or omissions or for any misinterpretation of the information within the publication & reserves the right to change without notice.

WL_FG_0818
IOM_JR0030_V2