



PECAT® 250mm Factory Entry Elbow

AG Series

APPLICATION

Provides a high strength transition fitting for connecting polyethylene gas pipe to a building via a steel 90° elbow and through wall pipe for an above ground connection.

DESCRIPTION

Comprising a PECAT® mechanical joint, factory assembled with straight length of PE pipe with a GRP protective cover sleeve, a through wall steel outlet with tight fit PE cover and a retaining clamp for tight fitment to the wall, terminating with a plain ended tube for on-site welding.

CONSTRUCTION

- Body (1), Sleeve (2) and Retaining Clamp (7): Steel
- Inlet Pipe (3) and Tight Fit PE cover (6): PE to GIS/PL2-2
- Cover Tube (4): GRP
- Cover Tube Support (5): EPDM Rubber
- Corrosion Protection: Zinc electrophoretic plating and Grey Polyester coating

SPECIFICATION

Meets GIS/PL3:2023 requirements, BSI Kitemark Certified – KM535530, Maximum Operating Pressure (MOP) = 2 bar.

Item Code	L1	L2
AG2136	345	425
AG2137	500	580
AG2138	610	690



INSTALLATION

Factory Entry Elbows supplied suitable for site joining by electrofusion only. Adjustment to entry height can be made by cutting PE (3) and GRP (4) tubes on site, no adjustment on through wall length is possible, see table below for available through wall length options. Please refer to PE fitting manufacturer's instructions for details on electrofusion welding procedures.

Every effort has been made to ensure that the information contained in this publication is accurate at the time of publishing. Crane Ltd assumes no responsibility or liability for typographical errors or omissions or for any misinterpretation of the information within the publication & reserves the right to change without notice.

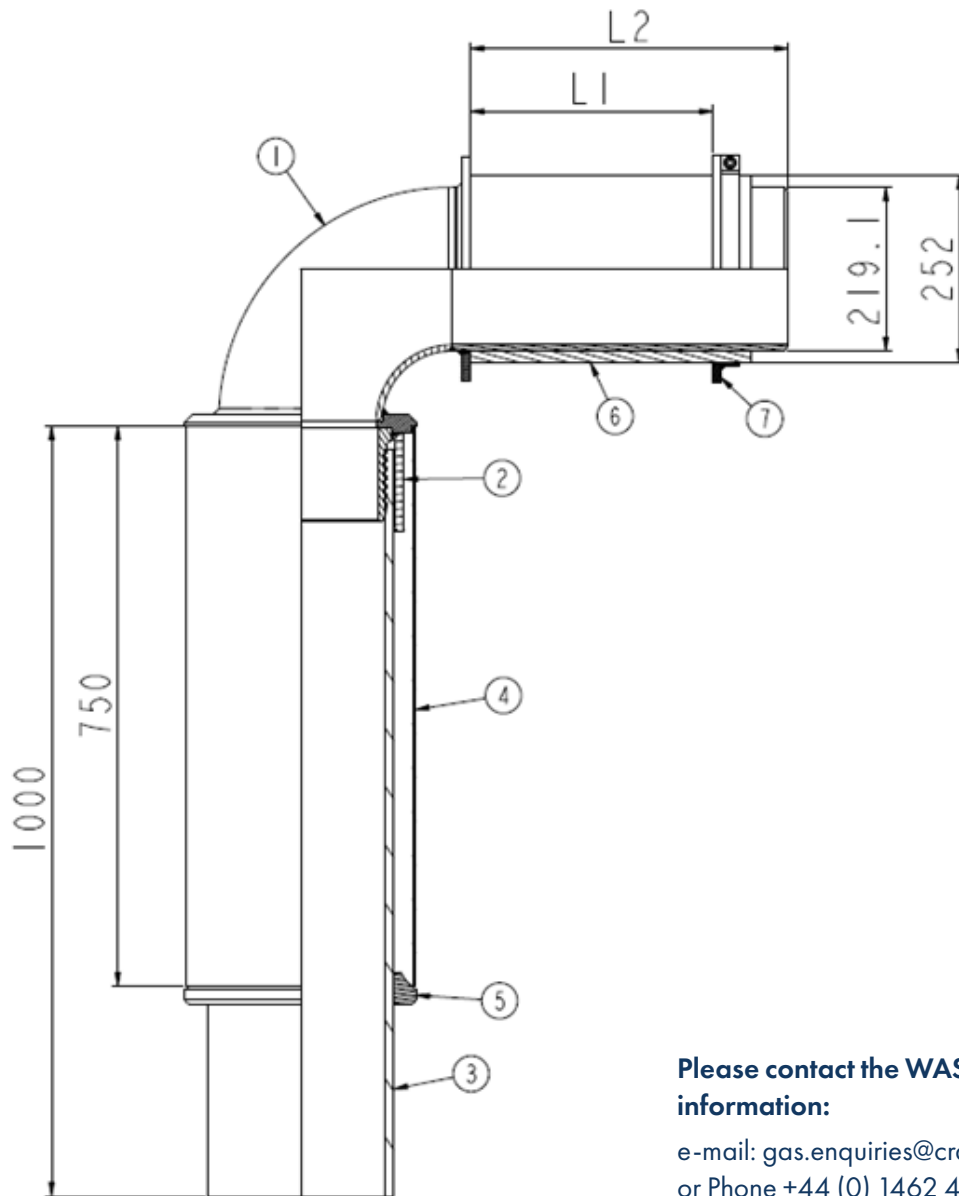

Please contact the WASK Sales team for further information:

e-mail: gas.enquiries@cranebsu.com
 or Phone +44 (0) 1462 443322



To visit our Video Library go to:
www.youtube.com/user/CraneBSU



46-48 WILBURY WAY, HITCHIN,
 HERTFORDSHIRE, SG4 0UD
 TELEPHONE: +44 (0)1462 443225
 TELEPHONE: +44 (0)1462 443226
 FAX: +44 (0)1462 443311
 EMAIL: sales@wask-uk.com
www.wask-uk.com

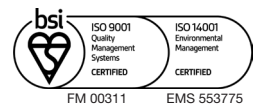

- Designed and manufactured under quality management systems in accordance with BS EN ISO 9001.

Every effort has been made to ensure that the information contained in this publication is accurate at the time of publishing. Crane Ltd assumes no responsibility or liability for typographical errors or omissions or for any misinterpretation of the information within the publication and reserves the right to change without notice.

W_FEE_0625_v1